

Motor Testbench

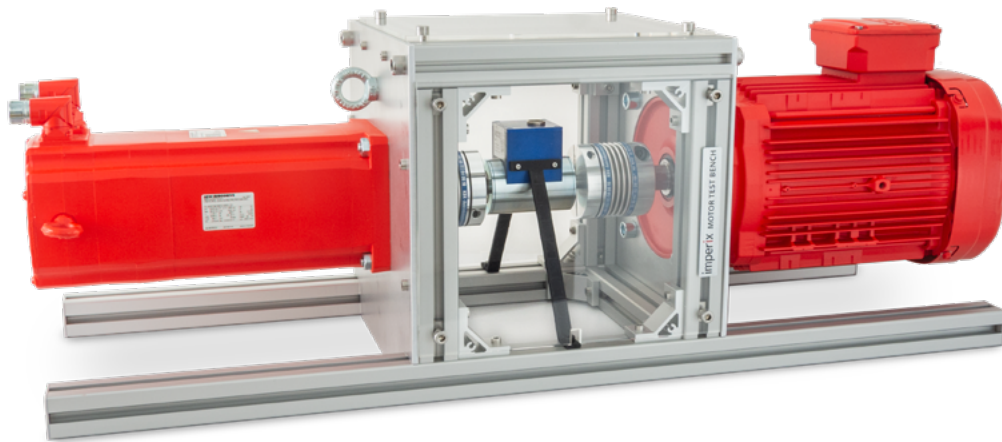

GENERAL DESCRIPTION

The Motor Testbench features a squirrel cage Induction Machine (IM) coupled to a Permanent Magnet Synchronous Machine (PMSM). It provides a convenient platform to validate innovative control techniques for high-performance variable speed drives: one machine is the device under test while the other one acts as a controllable load.

As a development tool, it features position, speed, and torque measurements as well as temperature monitoring of the machines. Additionally, the included brake allows locking the rotor. It can be used to either prevent the shaft from moving or perform emergency braking.

TYPICAL APPLICATIONS

The Motor Testbench was designed to develop and evaluate drive control techniques on one machine while the other one provides a programmable load. Fig. 1 illustrates how to use the testbench combined with other products from imperix to build a complete drive prototyping setup.

Imperix solutions allow emulating complex physical behaviors at a reduced scale. For example, the load machine could reproduce the torque applied by the air on a wind turbine, while the second machine plays the role of the generator. The same principle is applicable to electric car motor control, railway traction systems, etc.

KEY FEATURES AND SPECIFICATIONS

- » 4 kW squirrel cage induction machine for 380V/50Hz and 460V/60Hz operation
- » 4 kW permanent magnet synchronous machine for 400V/1800rpm operation
- » Resolver (position sensor)
- » Torque sensor
- » Built-in brake

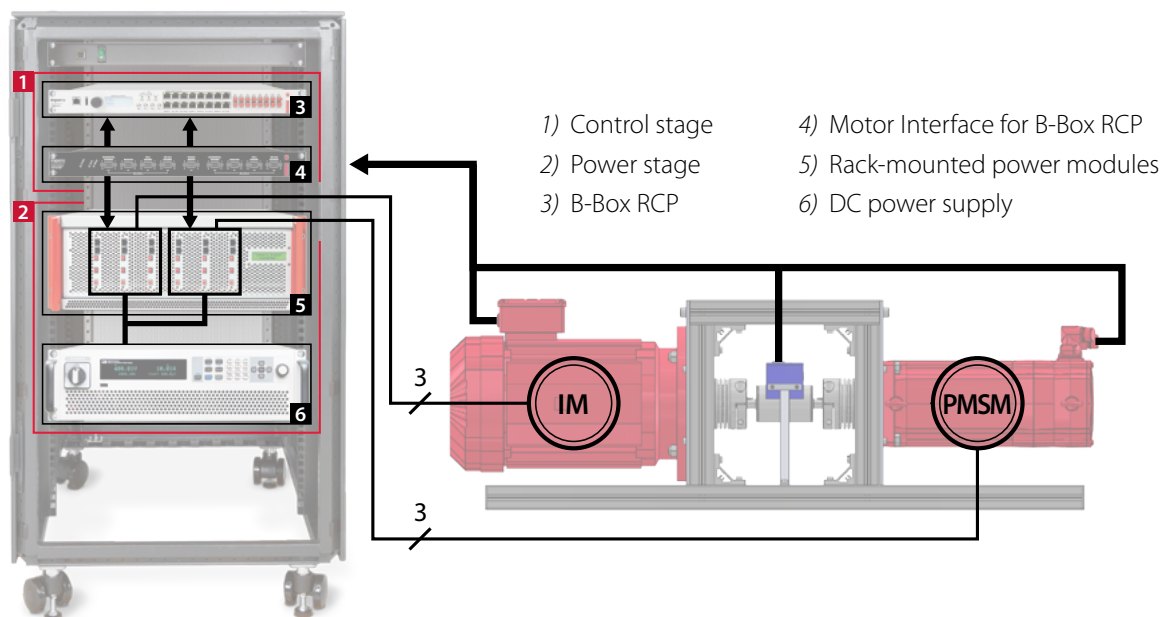

Fig. 1. Complete variable speed drive prototyping solution featuring the Motor Testbench.

DEVICE DESCRIPTION

The two machines are coupled together with a torque sensor placed in-between. As for the brake and the resolver, they are directly integrated into the PMSM. Fig. 2 illustrates the Motor Testbench and its parts.

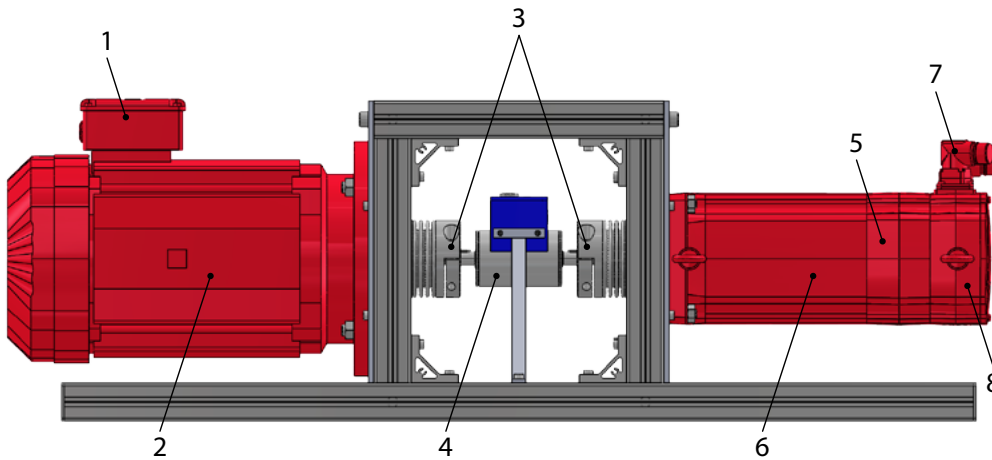

Fig. 2. Overview of the Motor Testbench.

- | | |
|----------------------------|--|
| 1) Terminal box IM (power) | 5) Brake |
| 2) Induction Machine | 6) Permanent Magnets Synchronous Machine |
| 3) Flexible couplings | 7) Power & signals plugs (PMSM) |
| 4) Torque sensor | 8) Resolver |

INDUCTION MACHINE

The induction machine is a DRN112M4 from SEW Eurodrive. It is rated for 380V/50 Hz and 460V/60 Hz operation, and Table 1 summarizes the main specifications of the IM.

Characteristic	Symbol	@ 50 Hz	@ 60 Hz	Unit
Pole pairs	p	2	2	-
Rated line voltage	V_{LLN}	380	460	V
Rated power	P_N	4	4	kW
Rated torque	M_N	26	21.5	Nm
Rated speed	n_N	1464	1769	rpm
Rated current	I_N	8.4	7.1	A
Power factor	$\cos \varphi$	0.81	0.79	-
Starting torque ratio	M_A/M_N	2.4	2.8	-
Starting current ratio	I_A/I_N	8.2	9.8	-
Moment of inertia	J_{mot}	178	178	kg cm ²

Table 1. Main specifications of the induction machine.

The stator is star-connected at the factory. However, since the windings are user-accessible, it is possible to wire them in a double-star or delta configuration. Please refer to the manufacturer's instructions on this topic.

MODELING OF THE MACHINE

The steady-state equivalent circuit of a squirrel cage induction is taken from the IEEE Standard 112-2017 as illustrated in Fig. 3.

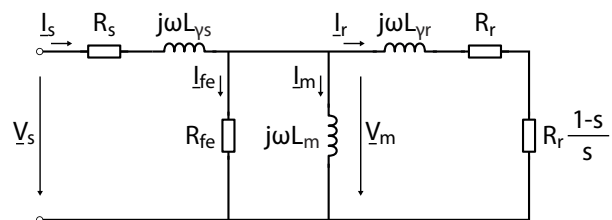

Fig. 3. Steady-state equivalent circuit of a squirrel cage induction machine.

The typical parameters of the DRN112M4 – from the manufacturer – are summarized in Table 2. For this machine, the iron resistance R_{fe} is negligible in comparison to the magnetizing branch $j\omega L_m$.

Characteristic	Symbol	Value	Unit
Stator resistance	R_s	1.24	Ω
Stator leakage inductance	L_{ys}	11.5	mH
Mutual inductance	L_m	183	mH
Rotor resistance ¹	R_r	0.73	Ω
Rotor leakage inductance ¹	L_{yr}	11.5	mH

Table 2. Parameters from the steady-state equivalent circuit of the induction machine.

¹ Rotor variables are referred to the stator side

THERMAL PROTECTION

There are no protections on the motor itself against overheating. However, a 4-wire PT1000 sensor is installed on one of its windings to provide temperature feedback to the drive. Table 3 summarizes the specifications of the sensor.

Connection	4 wires
Resistance @ 0 °C	1000Ω
Temperature coefficient	385 Ω / 100 °C
Test current	< 3 mA
Max. operating temperature	155 °C

Table 3. Specifications of the PT1000 temperature sensor.

PROVIDED CABLE

The testbench includes a five-meter-long power cable to supply the three phases of the IM (see Table 4). It also provides access to the neutral of the star connection, as well as a PE conductor. The cable has fixed wiring on the machine side and male banana plugs on the other end.

Color	Function description
Brown	Phase U
Black	Phase V
Grey	Phase W
Blue	Neutral
Yellow/green	Protection Earth

Table 4. Description of the power cable for the IM.

The temperature measurement is made available through a five-meter-long D-Sub 15 cable. The pinout is compatible with the Motor Interface for B-Box RCP (see Table 5).

Pins	Name	Direction	Function description
12	PT1000	Input	0.6 mA current source for PT1000
13	TEMP_P	Output	Positive terminal temperature sensor
14	TEMP_N	Output	Negative terminal temperature sensor
15	GND		Ground connection
	SHD		Earthed shield

Table 5. Pinout assignment of the signal cable of the IM.

PERMANENT MAGNET SYNCHRONOUS MACHINE

The permanent magnet synchronous machine is a CM3C80L from SEW Eurodrive with a star connection. Table 6 summarizes the main specifications of the machine.

Characteristic	Symbol	Value	Unit
Pole pairs	p	4	-
Rated line voltage	V_{LLN}	400	V
Rated power	P_N	4.8	kW
Rated torque	M_N	22.8	Nm
Rated speed	n_N	2000	rpm
Rated current	I_N	11.2	A
Maximum torque	M_{pk}	68.4	Nm
Maximum speed	N_{max}	2750	Rpm
Maximum current	I_{max}	34.9	A
Moment of inertia	J_{mot}	40.6	kg cm ²

Table 6. Main specifications of the synchronous machine.

MODELING OF THE MACHINE

The CM3C80L is an isotropic machine with surface-mounted magnets. As such, the phase inductance is the same along with the d and q axes of the Rotating Reference Frame (RRF). The steady-state equivalent circuit is illustrated in Fig. 4, and Table 7 summarizes the machine parameters.

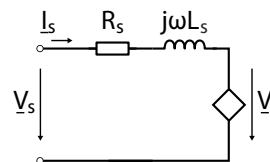

Fig. 4. Steady-state equivalent circuit of a PMSM with surface-mounted magnets.

Characteristic	Symbol	Unit	Value
Phase resistance	R_s	Ω	0.559
Phase inductance	L_s	mH	4.24
Permanent magnets flux	ψ_{PM}	Wb	0.2748
Internal voltage @ 1000 rpm	V_{i0}	$V_{LL,RMS}$	141

Table 7. Model parameters of the synchronous machine.

THERMAL PROTECTION

Like the IM, the synchronous machine does not have overheating protections inside the motor. However, it features a 2-wire PT1000 sensor for temperature feedback (see Table 3).

MECHANICAL BRAKE

The PMSM features a mechanical brake (BK3). Its intended purpose is to hold the rotor in place and prevent unintended movement of the shaft. However, it is also suitable for repetitive emergency braking. The brake is normally-on and requires a 24 V command to be released. Table 8 summarizes the specifications of the brake.

Characteristic	Symbol	Value	Unit
Maximum speed in case of emergency braking	$n_{br,max}$	6000	rpm
Nominal brake DC voltage (range)	$U_{br,N}$	24 (21.6 – 26.4)	V
Nominal braking torque	$M_{br,N}$	30	Nm
Dynamic braking torque	$M_{br,dyn}$	23.8	Nm
Response time	$t_{br,max}$	200	ms
Nominal holding current	$I_{br,H}$	0.94	A
Maximum braking work per emergency stop	$W_{br,max}$	1.2	kJ
Permitted braking work until maintenance	$W_{maintenance}$	2400	kJ
Moment of inertia	J_{br}	46.2	kg cm ²

Table 8. Specifications of the brake.

The working principle of the brake is illustrated in Fig. 5. When the coil is de-energized, permanent magnets in the brake create a force that holds the pressure plate against the friction disk of the shaft. The friction torque between the disk and the plate prevents the shaft from moving. Supplying a DC current into the brake coil cancels the magnetic field of the permanent magnets, and a spring-based mechanism pulls the pressure plate away from the friction disk, releasing the shaft.

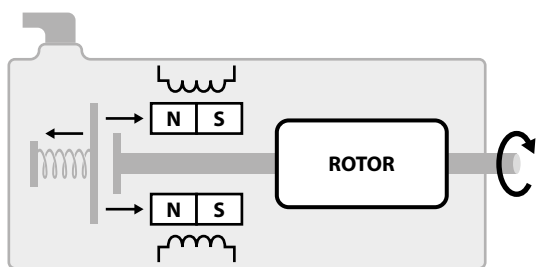

Fig. 5. Mechanical brake based on permanent magnets.

RESOLVER

The PMSM is equipped with a resolver (RH1M) to measure the position and speed of the rotor. Since the IM is coupled to the resolver, the latter provides the position of both machines. Table 9 summarizes the specifications of the resolver. Following IEC 60034-8, the position angle increases when the shaft rotates in the clockwise direction of the PMSM.

Pair of poles	1
Nominal excitation voltage	7V
Nominal excitation frequency	7 kHz
Gear ratio +/- 10%	0.5
Phase shift +/- 5°	+13°

Table 9. Specifications of the resolver.

PROVIDED CABLES

The testbench includes a five-meter-long power cable to supply the PMSM (see Table 10). It combines the three phases of the machine, a PE conductor and the brake command. The cable features an M23 round connector on the machine side and male banana plugs on the other end.

Color	Function description
Brown	Phase U
Black	Phase V
Grey	Phase W
Yellow/green	Protection Earth
Red (B+)	Brake +
Black (B-)	Brake -

Table 10. Description of the power cable for the PMSM.

CAUTION Adhere with the specified polarity of the power supply of the brake. Risk of damage.

» Check the polarity before connecting the brake.

The testbench also includes a five-meter-long signal cable that combines the resolver and temperature measurements. It features an M23 round connector on the machine side and a D-Sub 15 male connector (3 rows variant) on the drive end. The pinout assignment is compatible with the Motor Interface for B-Box RCP (connector X2 or X7). Table 11 indicates the pinout of the signal cable.

Pins	Name	Direction	Function description
1	SIN	Output	Negative SIN signal
2	COS	Output	Negative COS signal
4	EXC	Input	Negative excitation
6	SINLO	Output	Positive SIN signal
7	COSLO	Output	Positive COS signal
9	\EXC	Input	Positive excitation
13	TEMP_P	Output	Positive terminal temperature sensor
14	TEMP_N	Output	Negative terminal temperature sensor
	SHD		Earthed shield

Table 11. Pinout assignment of the signal cable of the PMSM.



DISCLAIMER

The signal cable of early units was wired such that the clockwise direction indicated by the resolver would correspond to the counterclockwise direction as defined in IEC 60034-8. Starting from July 2023, the signal cable of the PMSM was modified to be coherent with the standard.

COUPLINGS

Both machines are coupled to the torque sensor using KB4HC/80-89-N14-N28 bellows couplings from KBK Antriebstechnik GmbH. They provide a high torsional stiffness while allowing shafts misalignments.

Property	Value	Unit
Max. rotating speed	6900	rpm
Rated torque	80	Nm
Max. angular misalignment	2	°
Max. lateral misalignment	0.25	mm
Shaft diameter (torque sensor)	14	mm
Shaft diameter (machine)	28	mm
Moment of inertia	8.5	kg cm ²

Table 12. Properties of the couplings

TORQUE SENSOR

The testbench features a bidirectional torque sensor series 2200 from NCTE². Table 13 summarizes the specifications of the sensor.

Characteristic	Value	Unit
Supply voltage	6 - 28	V
Nominal torque	75	Nm
Signal at zero torque	5	V
Signal at positive nominal torque	9	V
Signal at negative nominal torque	1	V
Output bandwidth	1000	Hz
Accuracy	±1	%
Max. rotating speed	5000	rpm
Moment of inertia	0.49	kg cm ²

Table 13. Specifications of the torque sensor.

The five-meter-long cable included with the torque sensor is terminated by a D-Sub 9 connector. The pinout assignment is compatible with the Motor Interface (connector X5) and is indicated in Table 14. Additionally, the cable of the sensor makes multiple turn around a ferrite core to mitigate the effects of common-mode noise.

Pins	Name	Direction	Function description
1	TORQUE_P	Output	Positive torque signal
2	VCC		Vcc supply for sensor
6	TORQUE_N	Output	Negative torque signal
7	GND		Ground connection
	SHD		Earthed shield

Table 14. Pinout assignment of the torque sensor.

The use of flexible couplings allows a small misalignment of the shafts. As a result, the torque sensor has some backlash by design and can vibrate a little bit. This translates into an oscillation in the measurement at the mechanical frequency of the rotor.

RECOMMENDED OPERATING CONDITIONS

Since the machines do not have identical specifications, imperix recommends following the ratings indicated in Table 15. The goal is to stay within the nominal range of both motors while ensuring proper operation of the brake in case of emergency braking.

Characteristic	@ 50 Hz	@ 60 Hz	Unit
Recommended power	3.5	4	kW
Recommended torque	22.8	21.5	Nm
Maximum dynamic torque	23.8	23.8	Nm
Recommended speed	1464	1769	rpm
Maximum speed	2700	2700	rpm

Table 15. Recommended operating conditions for the Motor Testbench.

INSTALLATION

The Motor Testbench is a heavy product and requires adequate equipment to move and lift the product. Table 16 specifies the weight of the machines for indicative purposes. Improper handling of heavy loads could lead to injuries.

Object	Unit	Weight
DRN112M4	kg	46
CM3C80L	kg	18
Motor Testbench	kg	< 70

Table 16. Weight of the testbench and its machines.

To ensure the safety of persons, the Motor Testbench should be positioned at a safe distance and/or with adequate protective structures around it. Furthermore, install it on a vibration-free and rigid structure to prevent unwanted movement during operation.

Fig. 6 illustrates how to ground the setup: the cabinet and the Motor Testbench must be connected to the earth to ensure the electrical safety of the system. Additionally, earthing cables should be as short as possible and connected to a common ground to avoid ground loops.

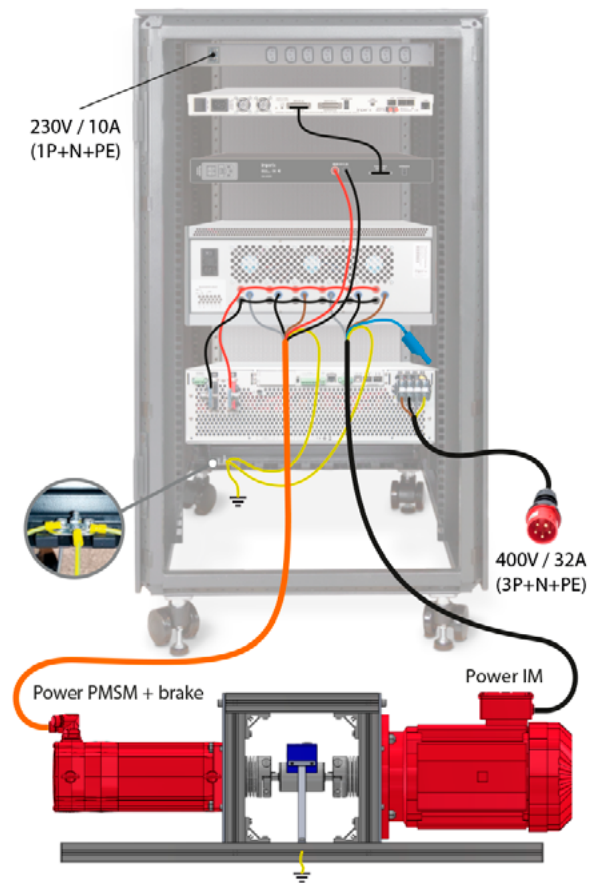

Fig. 6. Earthing connection of the Motor Testbench.

² The series 4000 is available as an option.

ENVIRONMENTAL CONDITIONS

The Motor Testbench is designed to operate under the conditions specified in Table 17.

Characteristic	Test conditions	Min.	Typ.	Max.	Unit
Operating temperature		0		60	°C
Storage temperature		-10		85	°C
Relative humidity	Non-condensing	5		85	%
Absolute humidity		1		25	g/m ³

Table 17. Environmental specifications for the Motor Testbench.

MECHANICAL DATA

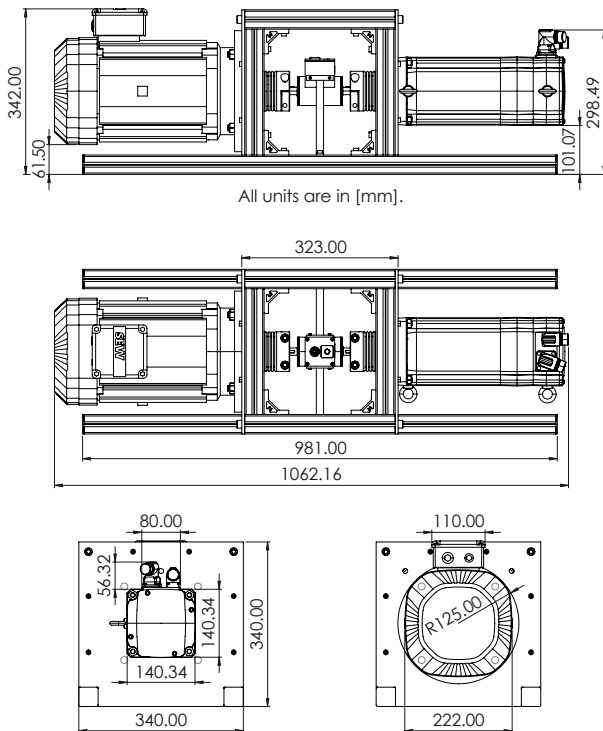

Fig. 7. Mechanical dimensions of Motor Testbench.

SAFETY NOTES



WARNING

High risk of electrical shock! Severe or fatal injuries.

- » Comply with applicable standards and safety requirements in accordance with the manufacturer's operating instructions.
- » Ensure that the product is used exclusively by qualified specialists.
- » All conducting parts must be inaccessible after installation.
- » Never plug or unplug any connectors while they are energized.
- » All devices must be properly connected to the protective earth.



WARNING

Risk of electric shock due to regenerative operation. Severe or fatal injuries.

- » Do not touch the pin contacts of power plugs.
- » The pin contacts of power plugs must be inaccessible.



WARNING

Severe or fatal injuries due to flying parts.

- » Parts connected or attached to the shaft must be secured.
- » Keys can skid out of their keyway.
- » Close the protective panels before startup.



WARNING

Risk of injury if the drives start up unintentionally. Severe or fatal injuries.

- » Always disconnect both motors from their drive before working on the machinery.
- » Make use of the brake to prevent unintended rotation of the shaft.



WARNING

Magnetic fields have a negative impact on pacemakers and other active medical implants. Health risk.

The synchronous machine has built-in permanent magnets that produce a magnetic field, even when power is switched off. Both machines generate additional electromagnetic fields during operation.

- » People with a pacemaker or any other active medical implants should keep a distance of at least 500 mm between the body part with the active medical implant and the motors.
- » Ensure that people with active medical implants are aware of the dangers.



WARNING

Risk of burns due to hot surfaces. Injury.

- » Make sure the unit has cooled down before touching it.
- » The motors must be installed in an adequately ventilated space to ensure proper cooling of the machinery.



WARNING

Adhere to the specified polarity of the power supply of the brake. Risk of damage.

- » Check the polarity before connecting the brake.



WARNING

Possible damage to the motor due to improper mounting.

- » Comply with applicable standards and safety requirements in accordance with the manufacturer's operating instructions.
- » Ensure that the product is used exclusively by qualified specialists.
- » Only install the motors in a horizontal position.
- » Place the testbench on a vibration-free and rigid support structure.
- » Secure the testbench on the support structure.
- » Properly align the shafts to prevent unacceptable strain.



CHECK-LIST

Before accessing the shaft or rewiring the unit.

- » Disconnect the power.
- » Secure the device against a restart.
- » Check that no voltage is applied.
- » Check that the product is properly grounded.
- » Secure live parts against accidental access.



CHECK-LIST

Before start-up.

- » Secure the product against unintended movements of individual parts or the assembly as a whole.
- » Close the protective panels.
- » Check that the product is properly grounded.
- » Secure live parts against accidental access.
- » Set appropriate external protections to prevent damage to the machinery (overcurrent, overvoltage, overtemperature, etc.).
- » Release the brake.

REVISION HISTORY

- » **21.02.22**: Preliminary version
- » **21.03.22**: New model of torque sensor and couplings
- » **12.05.22**: Additional details regarding the torque sensor and the coupling. Various fixes.
- » **24.07.23**: Correction of the permanent magnets flux and resolver's number of pair of poles. The direction of rotation indicated by the resolver was inverted to be coherent with IEC 60034-8.

CONTACT

imperix Ltd
Route des Ronquos 23
1950 Sion, Switzerland
phone: +41 (0)27 552 06 60
fax: +41 (0)27 552 06 69
www.imperix.com
support@imperix.com

ABOUT US

Imperix Ltd is a company established in Sion, Switzerland. Its name is derived from the Latin verb imperare, which stands for controlling and refers to the company's core business: the control of power electronic systems. Imperix commercializes hardware and software solutions related to the fast and secure implementation of pilot systems and plants in the field of power conversion, energy storage and smart grids.

NOTE

While every effort has been made to ensure accuracy in this publication, no responsibility can be accepted for errors or omissions. Data may change, as well as legislation, and the reader is strongly advised to obtain copies of the most recently issued regulations, standards, and guidelines. This publication is not intended to form the basis of a contract. Copyright 2022. All rights reserved.