

Motor Interface for B-Box RCP



KEY FEATURES AND SPECIFICATIONS

- » 2x Incremental encoder interfaces
- » 2x Resolver interfaces
- » 2x Hall sensors interfaces
- » 2x Sin/cos interfaces
- » 2x Temperature sensors
- » 1x Torque sensor interface
- » 1x 24Vdc brake command
- » 1x Electrical interlock

GENERAL DESCRIPTION

The Motor Interface is an extension of the B-Box RCP and supports a wide variety of sensors relevant to motor control applications. It is designed for use with a dual motor setup such as the imperix Motor Testbench.

The position and speed of each motor can be measured either by an incremental encoder, a resolver, hall sensors, or a sin/cos encoder. The Motor Interface also supports temperature measurements, as well as an optional torque sensor. Finally, a 24Vdc brake command and an interlock are available for safety purposes.

The 19" rack enclosure has the same format as the B-Box RCP and is connected to the latter through a single VHDCI digital cable.

TYPICAL APPLICATIONS

By design, the Motor Interface is tailored for use with a dual motor testbench. It provides position and temperature interfaces for two machines, as well as support for a brake and a single torque sensor. Generally speaking, it can be used for any motor application.

In this type of setup, one machine is the device under test while the other one acts as a variable load. This is an ideal configuration to test and validate innovative motor control techniques at a reduced scale. Fig. 1 illustrates how the Motor Interface is used to retrieve various measurement (speed, torque and temperature) from the imperix Motor Testbench.

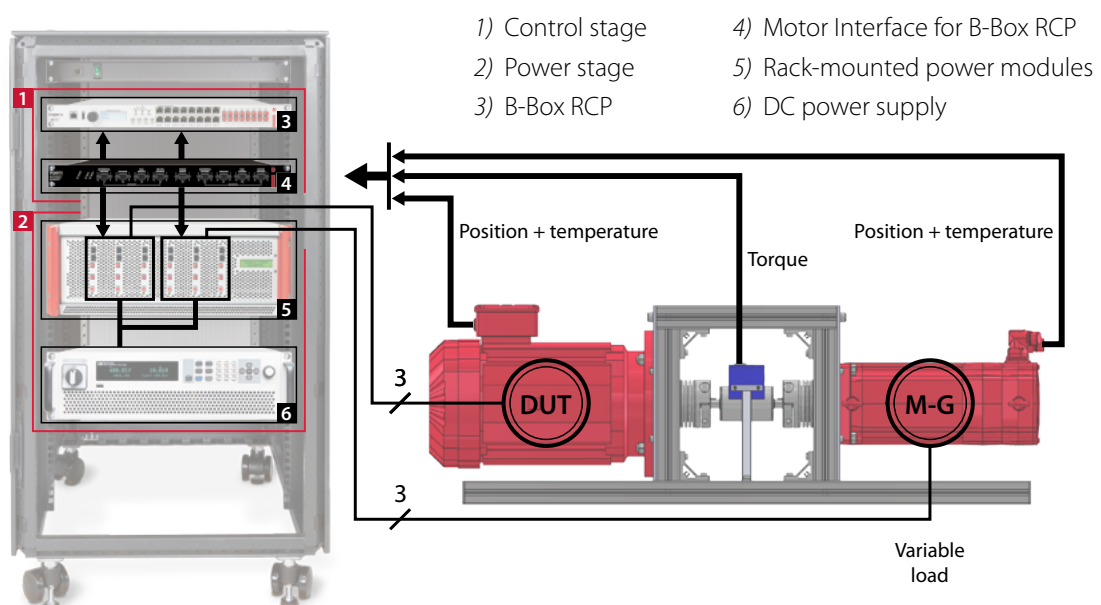

Fig. 1. Complete variable speed drive prototyping solution featuring the Motor Interface.

FRONT PANEL

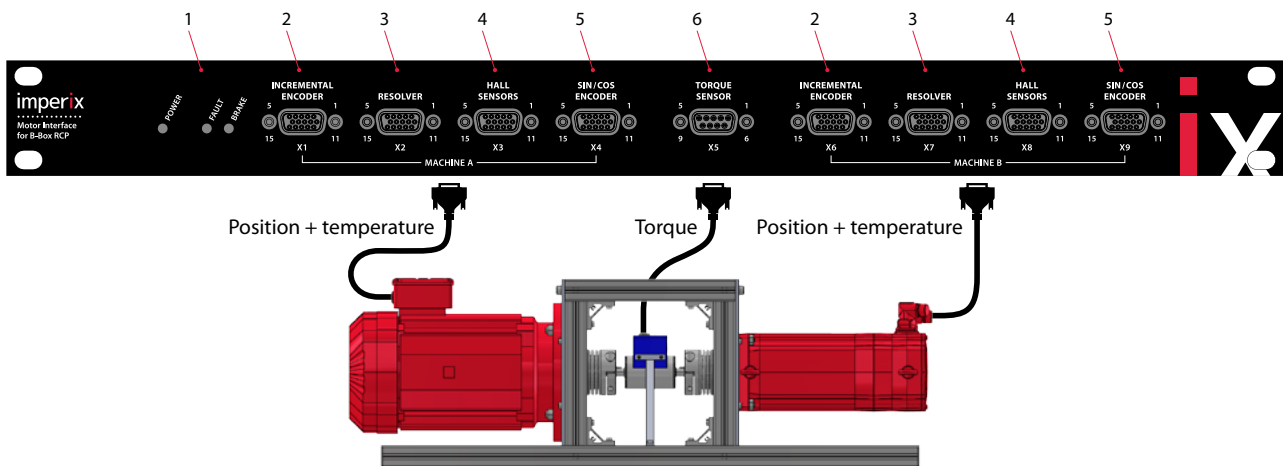

Fig. 2. Front view of the Motor Interface.

- | | |
|----------------------------------|------------------------------|
| 1) Status LEDs | 4) Hall sensors interface |
| 2) Incremental encoder interface | 5) Sin/cos encoder interface |
| 3) Resolver interface | 6) Torque sensor interface |

REAR PANEL

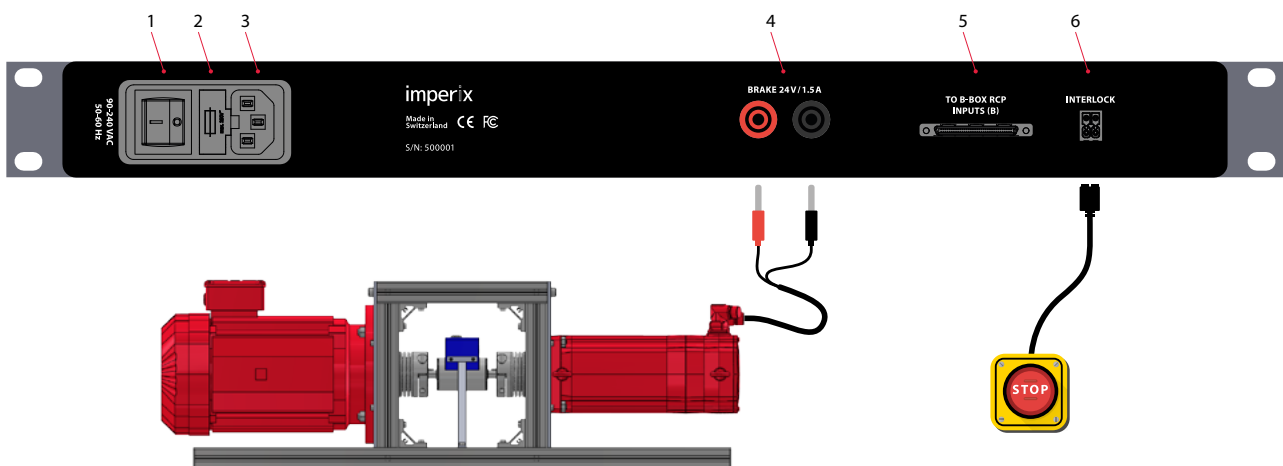

Fig. 3. Rear view of the Motor Interface.

- | | |
|--|--|
| 1) AC mains switch (ON/OFF) | 4) Brake command unit |
| 2) Fuseholder with 2x 2A fuses | 5) Interface with B-Box RCP (VHDCI HD68) |
| 3) AC mains socket (IEC C14, 110-230V) | 6) Electrical interlock connector (IN) |

FUNCTIONAL OVERVIEW

The Motor Interface is an extension of the B-Box RCP. As such, it provides the necessary signal conditioning electronics required by FPGA peripherals of the B-Box (refer to Fig. 4), as well as connectivity and power for external sensors. From a user perspective, resources from the Motor Interface are made available by the operating system (BBOS) as if they were fully built into the B-Box RCP. The Motor Interface is connected to the B-Box RCP on VHDCI inputs (B). Since the interface was designed for dual-motor setups, position and temperature measurements are duplicated and the machines are respectively labeled A and B.

- » **INC**: decoding of signals produced by an incremental encoder.
- » **RES**: provides the excitation circuit for a resolver, as well as decoding of the position.
- » **HAL**: acts as a pass-through for commutation signals produced by Hall sensors.
- » **S/C**: supports the analog-to-digital conversion of the signals produced by a sin/cos encoder.
- » **TMP**: provides temperature measurements by PT100 or PT1000 sensors.
- » **TRQ**: supports a single torque sensor with an analog output voltage.
- » **BRK**: offers a control unit for a single 24Vdc brake.
- » **INT**: offers an electrical interlock for connection with an emergency stop button.

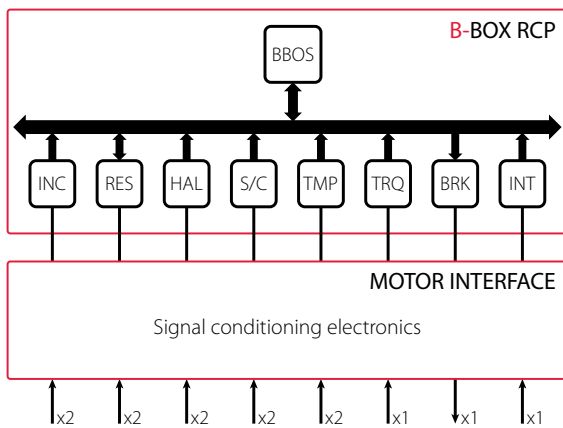

Fig. 4. Functional overview of the Motor Interface.



While the Motor Interface was designed with two machines in mind, all eight position sensor interfaces can operate simultaneously. There are no hardware or software limitations.

INCREMENTAL ENCODER INTERFACE

The Motor Interface supports up to two incremental encoders through the X1 and X6 connectors present on its front panel. The block diagram of the interface is presented in Fig. 5: incremental encoders are required to provide differential signals for better immunity to noise. However, the reset signal Z is still optional. In case the machine has a built-in temperature sensor, it can be accessed through the same connector as the position measurement. The pinout assignment of connectors X1 and X6 is indicated in Table 1.

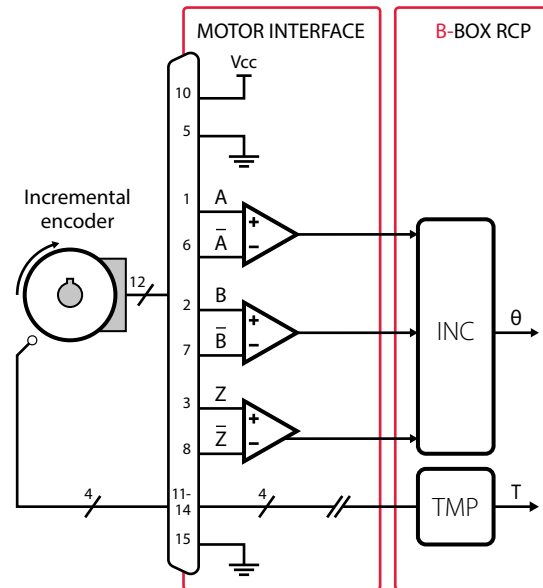

Fig. 5. Block diagram of the incremental encoder interface.

Pins	Name	Direction	Function description
1	A	Input	Encoder signal A
2	B	Input	Encoder signal B
3	Z	Input	Encoder signal Z (optional)
5	GND		Ground connection
6	\A	Input	Encoder signal \A
7	\B	Input	Encoder signal \B
8	\Z	Input	Encoder signal \Z (optional)
10	VCC		Vcc supply for encoder (5 or 12 V)
11	PT100	Output	6mA current source for PT100
12	PT1000	Output	0.6mA current source for PT1000
13	TEMP_P	Input	Positive terminal temperature sensor
14	TEMP_N	Input	Negative terminal temperature sensor
15	GND		Ground connection
	SHD		Earthed shield

Table 1. Pinout assignment of X1 and X6 (D-Sub 15).

The main specifications of the incremental encoder interface are summarized in Table 2. The encoder is supplied in 5V with optional support for 12V. While the Motor Interface requires differential encoders, the B-Box RCP still supports up to four single-ended sensors on VHDCI inputs (A) and (B). This is a legacy feature that is still supported by the B-Box RCP.

Characteristic	Test conditions	Min.	Typ.	Max.	Unit
Supply voltage ¹			5		V
Supply current				150	mA
Input signals	Differential		5		V
Maximum tolerable voltage (pins 1-3, 6-8)			14		V
Sampling options	Either synchronized with ADC, or independent				
PPR frequency	Quadruple rate	0		5	MHz

Table 2. Main specifications of the incremental encoder interface.

¹ 12V is available as an option. Contact sales@imperix.ch.

RESOLVER INTERFACE

The Motor Interface supports up to two resolvers through the X2 and X7 connectors present on its front panel. The block diagram of the interface is presented on Fig. 6: the position sensor is handled by a dedicated resolver-to-digital circuit (AD2S1210 from Analog Devices) that excitation signals and decode the differential SIN and COS inputs. In case the machine has a built-in temperature sensor, it can be accessed through the same connector as the position measurement. The pinout assignment of connectors X2 and X7 is indicated in Table 3.

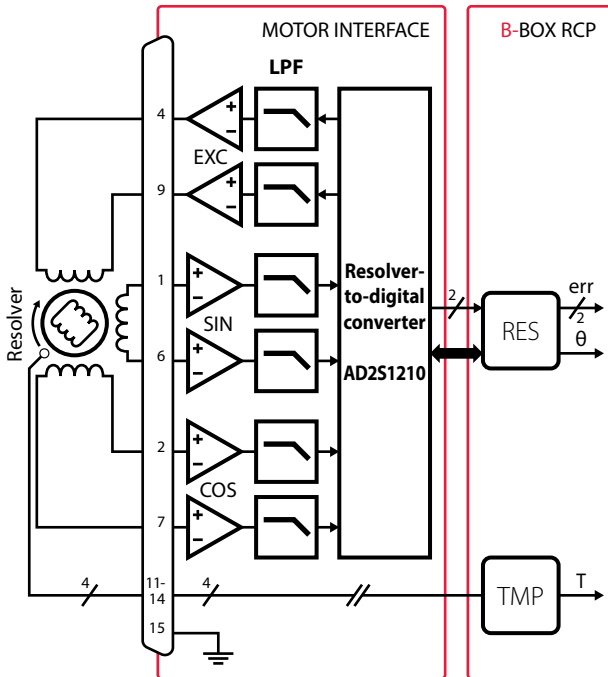

Fig. 6. Block diagram of the resolver interface.

Pins	Name	Direction	Function description
1	SIN	Input	Positive SIN signal
2	COS	Input	Positive COS signal
4	EXC	Output	Positive excitation
5	GND		Ground connection
6	SINLO	Input	Negative SIN signal
7	COSLO	Input	Negative COS signal
9	\EXC	Output	Negative excitation
11	PT100	Output	6mA current source for PT100
12	PT1000	Output	0.6mA current source for PT1000
13	TEMP_P	Input	Positive terminal temperature sensor
14	TEMP_N	Input	Negative terminal temperature sensor
15	GND		Ground connection
	SHD		Earthed shield

Table 3. Pinout assignment of X2 and X7 (D-Sub 15).

The main specifications of the resolver interface are summarized in Table 4. The sensor is excited by the AD2S1210 in 9Vp-p with 4.6Vp-p as an option. The excitation frequency and output resolution are set by default to 10kHz and 12-bit respectively.

Characteristic	Min.	Typ.	Max.	Unit
Excitation voltage ²	8	9	10	Vp-p
	4.1	4.6	5.12	Vp-p
Excitation current			150	mA
Excitation frequency (default)		10		kHz
Input voltage	4	4.5	5	Vp-p
	2.05	2.3	2.56	Vp-p
Input bandwidth		63		kHz
Maximum resolver phase shift		4		°
Maximum tolerable voltage (pins 1,2,4,6,7,9)		14		V
Output resolution (default)		12		bits

Table 4. Main specifications of the resolver interface.

HALL SENSOR INTERFACE

The Motor Interface supports up to two hall sensors through the X3 and X8 connectors present on its front panel. The block diagram of the interface is presented in Fig. 7: the commutation signals are passed-through with a simple level-shifting to meet the input voltage requirements of the B-Box RCP. In case the machine has a built-in temperature sensor, it can be accessed through the same connector as the position measurement. The pinout assignment of connectors X3 and X8 is indicated in Table 5.

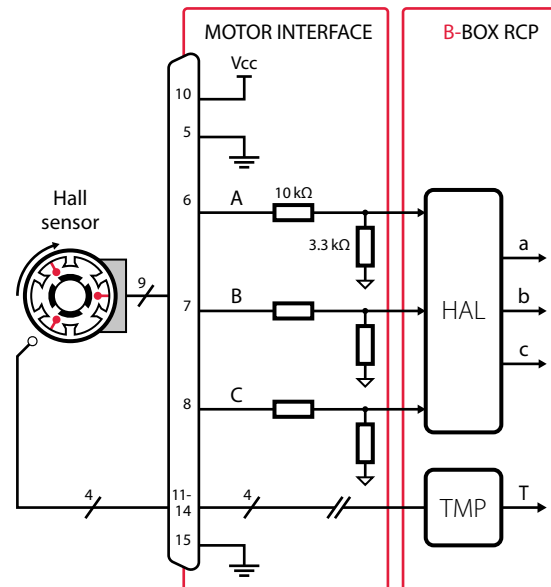

Fig. 7. Block diagram of the Hall sensor interface.

Pins	Name	Direction	Function description
5	GND		Ground connection
6	HALL_A	Input	Hall sensor phase A
7	HALL_B	Input	Hall sensor phase B
8	HALL_C	Input	Hall sensor phase C
10	VCC		Vcc supply for the Hall sensors (12 V)
11	PT100	Output	6mA current source for PT100
12	PT1000	Output	0.6mA current source for PT1000
13	TEMP_P	Input	Positive terminal temperature sensor
14	TEMP_N	Input	Negative terminal temperature sensor
15	GND		Ground connection
	SHD		Earthed shield

Table 5. Pinout assignment of X3 and X8 (D-Sub 15).

² 4.6V is available as an option. Contact sales@imperix.ch.

The main specifications of the hall sensor interface are summarized in Table 6. The sensors are supplied in 12V.

Characteristic	Min.	Typ.	Max.	Unit
Supply voltage		12		V
Supply current			150	mA
Maximum tolerable voltage (pins 6-8)		14		V

Table 6. Main specifications of the hall sensor interface.

SIN / COS ENCODER INTERFACE

The Motor Interface supports up to two hall sensors through the X4 and X9 connectors present on its front panel. The block diagram of the interface is presented in Fig. 8: the differential analog inputs are filtered and converted to digital values. The B-Box does currently not support decoding of sin/cos inputs: the raw signals are directly made available to the control software. Additionally, absolute sin/cos sensors are not supported³. In case the machine has a built-in temperature sensor, it can be accessed through the same connector as the position measurement. The pinout assignment of connectors X4 and X9 is indicated in Table 7.

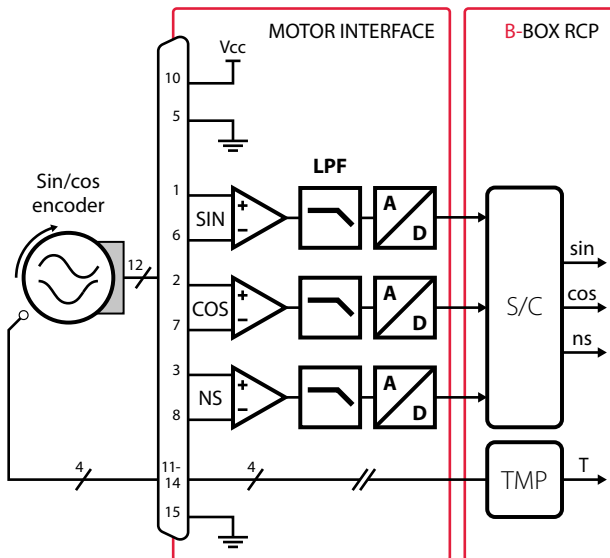

Fig. 8. Block diagram of the sin / cos encoder interface.

Pins	Name	Direction	Function description
1	SIN_P	Input	Positive SIN signal
2	COS_P	Input	Positive COS signal
3	NS_P	Input	Positive NS signal
5	GND		Ground connection
6	SIN_N	Input	Negative SIN signal
7	COS_N	Input	Negative COS signal
8	NS_N	Input	Negative NS signal
10	VCC		Vcc supply for encoder (5 or 12 V)
11	PT100	Output	6mA current source for PT100
12	PT1000	Output	0.6mA current source for PT1000
13	TEMP_P	Input	Positive terminal temperature sensor
14	TEMP_N	Input	Negative terminal temperature sensor
15	GND		Ground connection

Table 7. Pinout assignment of X4 and X9 (D-Sub 15).

The main specifications of the sin/cos encoder interface are summarized in Table 8. The encoder is supplied in 5V with optional support for 12V.

Characteristic	Min.	Typ.	Max.	Unit
Supply voltage ⁴		5		V
		12		V
Supply current			150	mA
Peak-to-peak differential voltage	0.8	1	1.2	V
Common mode voltage	-2	2.5	7.9	V
	-2	6	7.9	V
Maximum tolerable voltage (pins 1-3, 6-8)		14		V
Input bandwidth		103		kHz
Gain of analog chain		0.702		

Table 8. Main specifications of the sin / cos encoder interface.

TEMPERATURE SENSOR INTERFACE

The Motor Interface supports up to two PT100 or PT1000 temperature sensors. However, there is a subtlety since there is no dedicated connector for temperature measurements. Instead, the temperature sensor interface is accessible through connectors X1 to X4 for machine A, and through X6 to X9 for machine B. Please refer to the block diagram from Fig. 9. This configuration allows combining the position and temperature measurements in a single cable, whatever the type of position sensor.

PT100 and PT1000 have a linear resistance-to-temperature characteristic which is standardized by IEC 60751 (see Table 9). For this reason, they are much easier to calibrate than other types of temperature sensors such as NTCs or PTCs.

Characteristic	PT100	PT1000	Unit
Nominal resistance @ 0°C	100	1000	Ω
Temperature sensitivity	0.385	3.85	Ω/°C

Table 9. Standard specifications of PT100 and PT1000 resistors.

The value of the temperature sensing resistor is converted into a voltage by applying a constant current. Since the current sources of the Motor Interface have a zero temperature coefficient, the resulting voltage has a linear dependency on the temperature. The voltage is then converted to a digital value by an ADC.

Since the sensitivity of a PT100 is ten times smaller than for a PT1000 (see Table 9), the current applied to the PT100 must be ten times larger to preserve the resolution of the ADC. For this reason, the temperature sensor interface provides two different current sources on pins 11 and 12 (see Table 10).

³ Please contact imperix if you need to interface such a sensor (sales@imperix.ch).

⁴ 12V is available as an option. Contact sales@imperix.ch.

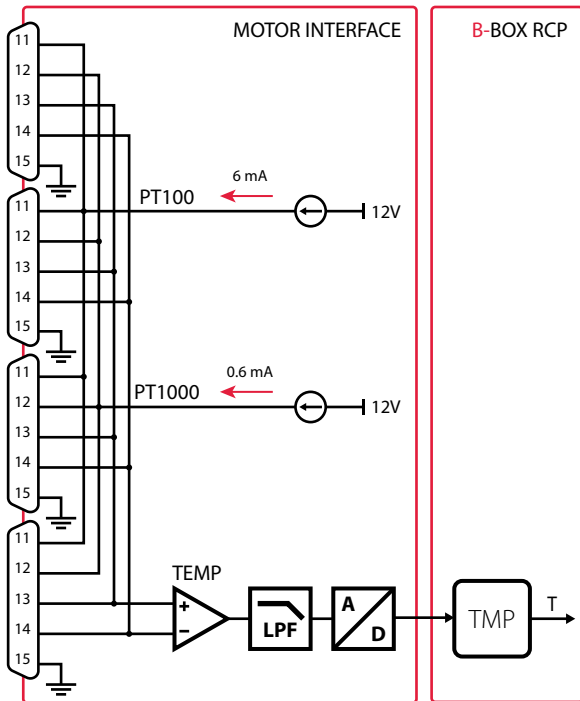

Fig. 9. Block diagram of the temperature sensor interface.

Pins	Name	Direction	Function description
11	PT100	Output	6mA current source for PT100
12	PT1000	Output	0.6mA current source for PT1000
13	TEMP_P	Input	Positive terminal temperature sensor
14	TEMP_N	Input	Negative terminal temperature sensor
15	GND		Ground connection
	SHD		Earthed shield

Table 10. Pinout assignment for the temperature sensor interface.

The user is responsible of wiring the sensor according to its needs. To this end, it is highly recommended to use a D-Sub 15 connector with built-in terminal block headers. The wiring schemes for PT100 and PT1000 sensors are illustrated in Fig. 10 and 11 respectively: the appropriate current source is manually connected to the sensor while pin 15 provides a return path for the current. Then, two additional wires are used to measure the voltage drop over the sensing resistor.

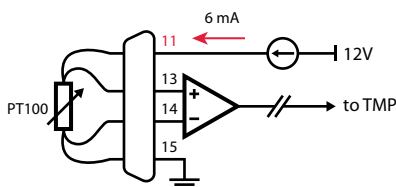

Fig. 10. Wiring scheme for a 4-wire PT100 sensor.

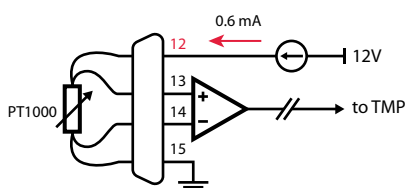

Fig. 11. Wiring scheme for a 4-wire PT1000 sensor.

The main specifications of the temperature sensor interface are indicated in Table 11.

Parameter	Min.	Typ.	Max.	Unit
Operating range	0		150	°C
Input voltage	0.6		1	V
Maximum tolerable voltage (pin 13, 14)		1.2		V
Input bandwidth		457		Hz
Gain of analog chain		1		

Table 11. Main specifications of the temperature sensor interface.

Some temperature sensors only have two wires. In this case, the current source is bridged to TEMP_P and TEMP_N is connected to the ground. Fig. 12 illustrates the wiring scheme adapted for 2-wire temperature sensors.

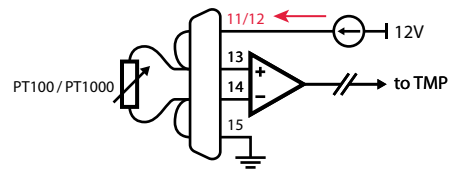

Fig. 12. Wiring scheme for a 2-wire temperature sensor.

As for 3-wire sensors, they are not supported by the Motor Interface and must be wired as a two wire sensor. Fig. 13 illustrates the principle.

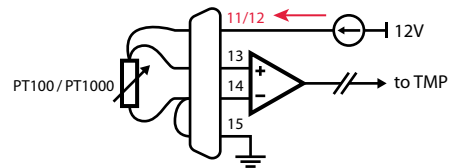

Fig. 13. 3-wire temperature sensor on a 2-wire interface.

TORQUE SENSOR INTERFACE

The Motor Interface supports a single torque sensor through the X5 connectors present on its front panel. The block diagram of the interface is presented in Fig. 14: the input voltage from the sensor is filtered and converted to a digital value. The pinout assignment of connectors X5 is indicated in Table 12.

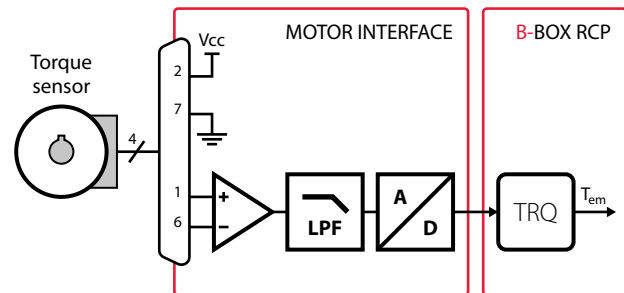

Fig. 14. Block diagram of the torque sensor interface.

Pins	Name	Direction	Function description
1	TORQUE_P	Input	Positive torque signal
2	VCC	Power	Vcc supply for sensor (12 or 24 V)
6	TORQUE_N	Input	Negative torque signal
7	GND	Power	Ground connection
	SHD		Earthed shield

Table 12. Pinout assignment of X5 (D-Sub 9).

The electrical specifications of supported torque sensors are summarized in Table 13. The sensor is supplied in 12V with optional support for custom voltages. Additionally, the specifications of the analog chain from the interface can be found in Table 14.

Output signal	Value	Unit
Supply voltage ⁵	12	V
Supply current	< 200	mA
Signal at zero torque	0	5
Signal at positive nominal torque	5	7.3
Signal at negative nominal torque	-5	2.7

Table 13. Electrical specifications of supported torque sensors.

Parameter	Min.	Typ.	Max.	Unit
Differential input voltage		10		V
Common-mode input voltage	-1.4		8.5	V
Maximum tolerable voltage (pin 1, 6)	-14		14	V
Input bandwidth		103		kHz
Gain of analog chain		0.0856		V

Table 14. Main specifications of the torque interface.

BRAKE CONTROL INTERFACE

The Motor Interface features a brake control unit that delivers a 24 Vdc command through two banana plugs on its rear panel. The block diagram of the interface is presented in Fig. 15: the brake is expected to be active by default and released by energizing its coil. The color of the banana plugs indicates the polarity of the brake: red for the positive terminal and black for the negative one.

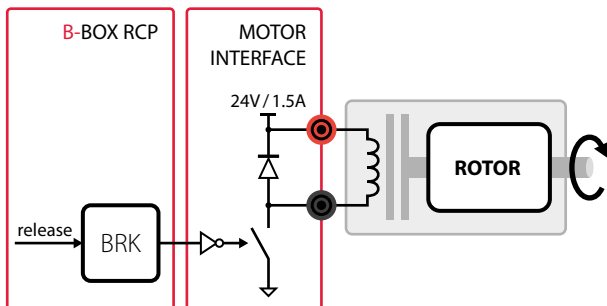

Fig. 15. Block diagram of the brake control interface.

The main specifications of the brake control unit are summarized in Table 15. It delivers 24Vdc with a maximum continuous current of 1.5 A.

Symbol	Characteristic	Min.	Typ.	Max.	Units
V_{cc}	Brake supply voltage		24		V
I_{out}	Continuous output current		1	1.5	A

Table 15. Main specifications of the brake control unit.

Depending on the model, the DC command directly energizes the coil (see Fig. 15). However, many brakes require an AC power supply combined with a rectifier. In the latter case, the 24 Vdc command enables an AC relay (see Fig. 16). The AC supply and relay are external to the Motor Interface and sized according to brake requirements.

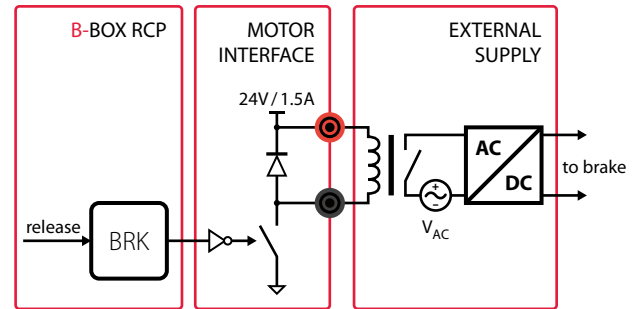

Fig. 16. Brake with an external supply

On early units, the brake is temporarily released while loading a new code into the B-Box. A future hardware revision will fix this behavior.

ELECTRICAL INTER-LOCK

Fault inter-locking allows coordinating emergency mechanisms between the B-Box RCP and the Motor Interface extension. The electrical inter-lock is accessible on the rear panel through a connector from Phoenix Contact (part number 1786837; mating part is 1790108). The block diagram of the interface is presented in Fig. 17: opening the emergency stop button triggers a fault at the FPGA level. The performance specifications of the electrical inter-lock are indicated in Table 16.

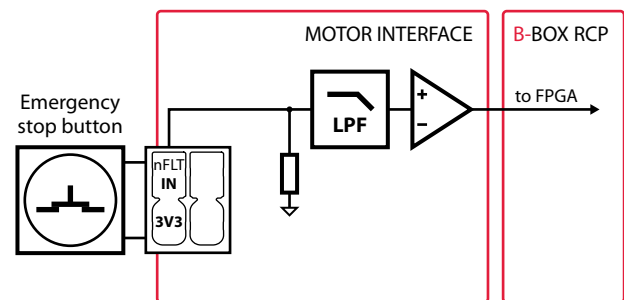

Fig. 17. Block diagram of the electrical inter-lock

Characteristic	Min.	Typ.	Max.	Unit
Operating voltage	3	3.3	3.6	V
Response delay to blocking of PWM signals			14.5	ms

Table 16. Performance specifications of the inter-locking mechanism

5 Custom voltages are available as an option. Contact sales@imperix.ch.

STATUS LEDS

The enclosure has three LEDs on the front to indicate the status of the Motor Interface.

- » **POWER**: power indicator. The LED is green when AC supply is ON.
- » **FAULT**: fault status of the motor interface.
- » **BRAKE**: status of the brake control unit.
 - **Green**: the brake is enabled and the shaft is safely locked.
 - **Orange**: the brake is disabled and the shaft can rotate freely. Risk of injury!

 **WARNING**
 Risk of injury if the drives start up unintentionally. Severe or fatal injuries.

- » If the motor is equipped with a brake, make use of the brake control unit of the Motor Interface to prevent unintended rotation of the shaft.
- » Make sure the holding torque of the brake is large enough to properly lock the shaft.

SOFTWARE SUPPORT

The Motor Interface requires a B-Box RCP with a valid license for the C++ or AGG SDKs. The C++ API and the Simulink and PLECS blocks are available starting from version 3.7.1.4 of the SDK.

ENVIRONMENTAL CONDITIONS

The Motor Interface for B-Box RCP is designed to operate under the conditions specified in Table 17.

Characteristic	Test conditions	Min.	Typ.	Max.	Unit
Input voltage		90		240	V
Input voltage		47		63	Hz
Power consumption				90	W
Operating temperature		0		45	°C
Storage temperature		-10		85	°C
Relative humidity	Non-condensing	5		85	%
Absolute humidity		1		25	g/m3

Table 17. Environmental specifications for the Motor Interface.

REVISION HISTORY

- » **02.21.22**: Preliminary version
- » **09.13.22**: Additional details regarding the software support. Various fixes.

CONTACT

imperix Ltd
 Route des Ronquos 23
 1950 Sion, Switzerland
 phone: +41 (0)27 552 06 60
 fax: +41 (0)27 552 06 69
 www.imperix.com
 support@imperix.com

ABOUT US

Imperix Ltd is a company established in Sion, Switzerland. Its name is derived from the Latin verb imperare, which stands for controlling and refers to the company's core business: the control of power electronic systems. Imperix commercializes hardware and software solutions related to the fast and secure implementation of pilot systems and plants in the field of power conversion, energy storage and smart grids.

NOTE

While every effort has been made to ensure accuracy in this publication, no responsibility can be accepted for errors or omissions. Data may change, as well as legislation, and the reader is strongly advised to obtain copies of the most recently issued regulations, standards, and guidelines. This publication is not intended to form the basis of a contract. Copyright 2021. All rights reserved.

MECHANICAL DATA

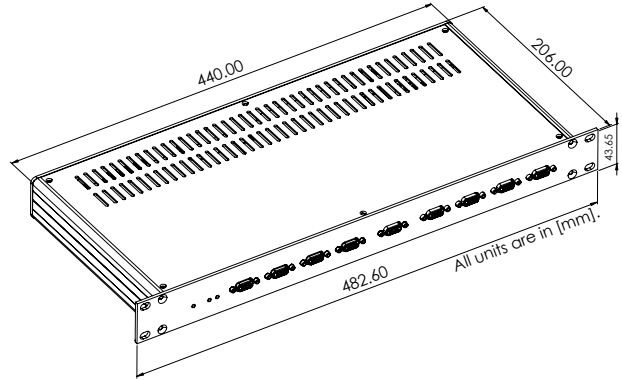



Fig. 18. Mechanical dimensions of the Motor Interface.

SAFETY NOTE

 **WARNING**
 This product must be used in electric / electronic equipment with respect to applicable standards and safety requirements in accordance with the manufacturer's operating instructions. Caution, risk of electrical shock! When using the devices, certain parts of the modules may carry hazardous voltages (e.g. power supplies, busbars, etc.). Disregarding this warning may lead to injury and/or cause serious damage. All conducting parts must be inaccessible after installation.